

INDUSTRIAL PRODUCTS STRADDLE CARRIER



PIERCE

WORK IN A MORE STABLE ENVIRONMENT WITH PIERCE STRADDLE CARRIERS.

Raising the carbody allows the excavator to literally unload by straddling railcars. The result... radical productivity gains over traditional side loading equipment, 3 times more! This is due to optimizing operator visibility and safety while minimizing damage to railcars. Furthermore, the cost is less than other railcar dump systems, and implementation is a snap.

See how simple it is to elevate your game – and your productivity.

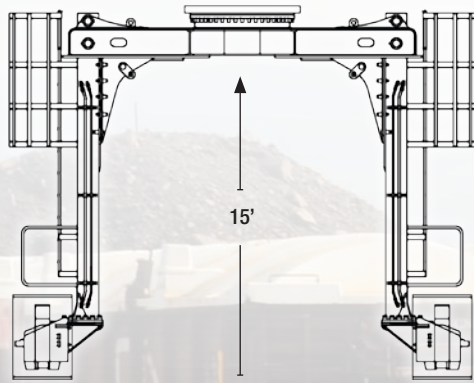

STANDARD RAILCAR CLEARANCE

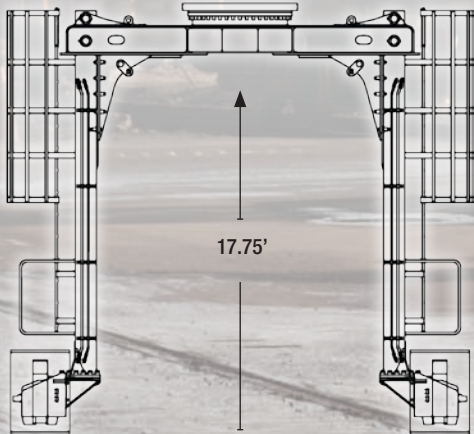

HI-TOP/LOCOMOTIVE CLEARANCE



STRADDLE CARRIER



PIERCE

In-house design team: check. Comprehensive manufacturing capabilities: check. Product testing and certification, technical support, and convenient distribution centers throughout North America: check, check, and check. With so much to offer, we're ideally positioned to provide complete solutions for all of your business needs. From ordinary to extraordinary.

As a leading designer and manufacturer of hydraulic excavator attachments and work tools, Pierce has built a solid reputation for providing reliable, high performance products that are designed to keep pace with changing industry conditions – and one step ahead of emerging technologies.

Our position as a direct supplier for many of the world's leading equipment providers has enabled us to become experts in client collaboration, managing specific application parameters, and maintaining the highest quality standards for a variety of markets. Even if your needs call for a customized solution that doesn't currently exist, you can count us to make it happen – and make it happen right. Imagine that.



Pierce Pacific Manufacturing, Inc.

4424 NE 158th
Portland, Oregon 97230 USA

Post Office Box 30509
Portland, Oregon 97294 USA

Telephone: 503.808.9110
Toll Free: 800.760.3270
Fax: 503.808.9111

Distribution Warehouse:
Jackson, Mississippi USA

www.piercepacific.com

